



healthtec

Supporting you

1300 362 923

www.healthtec.com.au

TREATMENT RANGE

Electric Postural Drainage Treatment Table

Ideal for physiotherapy, massage or manipulation techniques. This three-piece treatment table offers multiple positioning.

The manually adjustable head section with face hole can adjust from -90° to +45° with the leg section manually adjusting from flat to +70° while the electrically operated postural drainage function allows for a greater range of treatments to be performed.



FEATURES

- Electric height adjustment with footswitch
- X-frame lift action minimises pinch and crush points
- Heavy duty individually lockable castors
- Durable powder coated rust resistant frame
- High quality anti-microbial vinyl & CFC free foam
- Electric operated postural drainage
- Nose hole in headrest as standard

SPECIFICATIONS

WIDTH	610mm
LENGTH	1840mm
FOAM	50mm
VINYL	PVC (tested to AS1530.3)
HEIGHT RANGE	450mm to 950mm
HEIGHT SPEED	Full height within 16 seconds
LIFT CAPACITY	250kg (moving)
SAFE WORKING LOAD	400kg (stationary)
BASE	LynX X-Frame with castors
CONTROLLER	Footswitch
WARRANTY	5 year Electrical Lifetime Structural (parts only)

AVAILABLE ACCESSORIES



Procedure Arm



Paper Towel Roll Holder



Gynae Leg Supports



The Healthtec Warranty

Healthtec offers a lifetime warranty on all our manufactured tables and a five year warranty on motors and foot switches from date of purchase. Original suppliers warranty applies.

ARTG 132667

© August 2018





Supporting you

www.healthtec.com.au

PRICE SHEET

Electric Postural Drainage Treatment Table

Product Description	CODE	QTY
LynX Electric Postural Drainage Treatment Table – Three Section (610 wide) w/ castors	53031T-PD-6	
Width Options		
660mm Width Option	-65	
760mm Width Option	-75	
Custom Width Option	6014	
Foam & Vinyl Options		
75mm Comfort Foam	6005	
Non-Stock Vinyl Option	6018	
*please refer to our colour chart for vinyl colour options		
Head Section Options		
Nose Hole – Extra (footend)	6011	
Nose Hole Plug	6010	
Armrest & Footrest Options		
Procedure Arm	5112	
Footrest Extension	5104	
Footswitch Options		
Additional Double Footswitch (2 Function)	6024	
Table Protection		
Paper Towel Roll Holder	6017	
Extended Warranty		
10 Years on Electrical	7800	
Freight		
Freight charges are not included in our prices. Please contact your Healthtec representative for freight costs and options.		
Shipping Dimensions	2050mm x 850mm x 650mm	
Shipping Weight	80kg (approximately)	

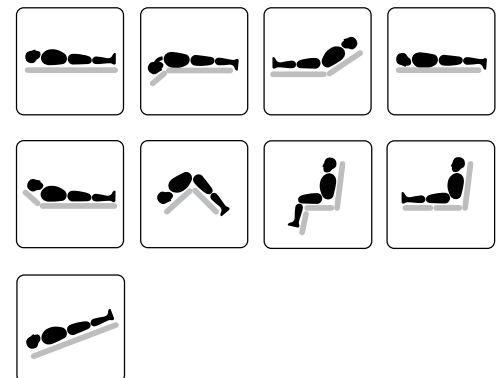
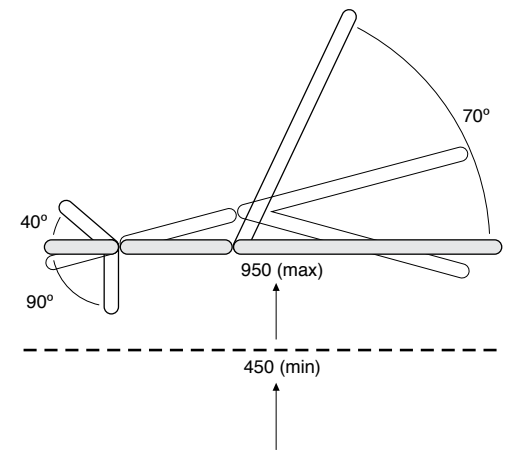
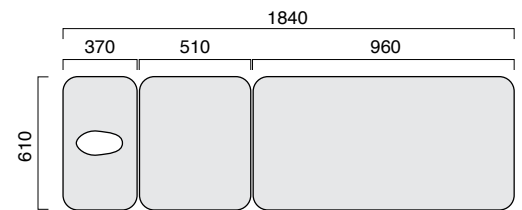

FRECALL
1300 362 923
info@healthtec.com.au



Healthtec Pty Ltd ABN 94 224 518 379 ARTG 132667
© August 2018

Disclaimer: Due to our policy of constant product improvement, specifications may change without notice. Check with us for the latest specifications and pricing.